

\$5.00

# Technical Bulletin & Troubleshooting Guide



The logo features the letters 'MBM' in a bold, white, sans-serif font. The letters are set against a dark, circular background that resembles a globe with latitude and longitude lines. The globe is surrounded by several concentric, glowing white rings that create a sense of depth and motion. A registered trademark symbol (®) is located to the right of the globe.

**MBM**®

*There are other companies almost kind of like us.  
You owe it to yourself to discover the MBM Advantage.*

# Table of Contents

## Brake Bleed Guide

Bench Bleeding and Testing the Master Cylinder .....Page 4

Bleeding the Lines .....Page 6

## Brake Troubleshooting

Troubleshooting Chart.....Page 7

Troubleshooting Bleeding Difficulties.....Page 10

The Right Valves.....Page 10

Check Booster Pushrod Adjustment .....Page 11

Check Flexible Brake Hoses.....Page 12

Check Pedal Assembly .....Page 12

Check Proper Alignment .....Page 13

Master Cylinder Test .....Page 13

Power Brake Booster Test .....Page 14

Combination Prop Valve Test.....Page 15

Sticking Proportioning Valve .....Page 15

Brake Fade .....Page 16

## Typical Brake System Configurations

Quick Reference Guides.....Page 16

**Caution**  
We encourage you to understand that the installation of any component or kit should only be performed by a person that is experienced in the proper operation of brake systems. Further, the responsibility for determining the suitability of a component or kit is your responsibility.

**Be Safe**  
We strongly encourage you to test your brakes under a controlled condition, before operating the vehicle. Several stops in a safe area at low speeds should be made and then gradually work up to normal speeds. Obviously, no one should drive with an untested brake system.

© Copyright 2006 by  
M B Marketing & Manufacturing, Inc.  
No reproduction, digital or otherwise  
can be made of any part of this catalog  
without express written authorization.

# Brake Bleed Guide

**Read these instructions carefully and completely before installing your Disc Brake Kit. This guide is set up to be generally followed in order. Here are a few basics to help ensure a safe brake system:**

- Following the steps in this guide will ensure that you will easily pinpoint any trouble spots in your brake system while installing and assembling the system, eliminating many headaches. “Follow it to the T,” and we are certain you will have a pleasurable experience with your upgrade.
- Use only new brake fluid. Contaminated fluid can cause damage to the sensitive hydraulic brake components during the bleeding process, corrode components and increase the likelihood of system failure. Even unused fluid that was opened at an earlier time should not be used. Brake fluid is hydroscopic meaning that it absorbs moisture from the air. This moisture degrades the properties of the brake fluid.
- Cleanliness is very important. Make sure you clean the fittings and surrounding area before opening any part of the brake system to keep contaminants from entering the fluid.
- For power brake upgrades, be sure to check for a minimum of 18 in. of vacuum prior to performing the upgrade. Vehicles with tall heads or superchargers most likely will not have sufficient vacuum. If you do not have sufficient vacuum, check your intake manifold for clogging, vacuum fittings and for collapsed vacuum lines. Also ask us about our 12 volt vacuum pump.
- Never eliminate loops from vacuum lines as these act as moisture and vapor traps. Check the vacuum lines for gas odor or the presence of moisture. Gas fumes can deteriorate the internal rubber components of the booster.
- Do not use petroleum-based solvents to clean brake components. Use only cleaning fluids specifically designed for brakes since they leave no residue when they dry.
- Do not use compressed air to dry brake components, even filtered air may contain moisture or traces of oil.
- Check brake lines for cracked, leaking or swollen lines. These must be replaced.
- Do not move or drive the vehicle until a firm pedal is established.

## ————— Bench Bleeding and Testing the Master Cylinder —————

Many people skip this VITALLY important step in bleeding their brake system. Bench bleeding the master cylinder **MUST** be performed any time a master cylinder is installed. If the master cylinder is not bled, it will take you at least twice as long to bleed the system and then there is no guarantee that you have removed all the air from the system. The master cylinder test is a preliminary precaution and may need to be performed at a later time should there be a need for further troubleshooting.

**DO NOT SKIP THIS STEP!** *Failure to follow these procedures is unsafe and may void your warranty!*

1. All new master cylinders from MBM include a bench bleeding kit that includes everything you need to perform the bench bleeding process.

2. Before bench bleeding the master, completely install all of your brake components and upgrades including the master cylinder and brake lines. This is so that you can hook up the master cylinder as soon as possible after it has been bench bled to keep gravity from leeching fluid from it during the installation of the other components.
3. After installing the system, remove the master cylinder completely from the vehicle. Master cylinders **MUST** be bench bled outside the vehicle and without any other components attached. This means that if the kit is shipped with a booster, proportioning valve and plumb lines attached to the master cylinder, they must all be removed prior to bench bleeding.
4. Be sure to place the master cylinder level in a vice to secure it properly. If the master cylinder is not level, not all the air will be able to be removed from the master cylinder. This is one of the main reasons we bench bleed the master cylinder off of the vehicle, to get it perfectly level during the bleeding process. Remove the master cylinder top and fill it with brand new brake fluid to the appropriate level as indicated in the master cylinder. This is generally about 1/2" - 1" from the top of the reservoir lip to allow for thermal expansion of the brake fluid.
5. Insert the plastic fittings that fit into the two side ports of the master cylinder, (Note: on dual ported master cylinders where there are four ports, choose one side and use both ports on that one side to perform the bleed process.) Insert one rubber tube into each of the plastic fittings and the loose ends should be inserted into the master cylinder reservoir. The plastic tab should be used to hold the tubes in place by slipping it over the reservoir separator and the hoses through the round holes.
6. Cover the top of the master cylinder with a rag to help prevent fluid from splattering, protecting your person as well as your vehicle. Be aware that brake fluid is mildly corrosive and may damage painted surfaces.
7. Using a wooden dowel or a blunt metal rod, compress the master cylinder plunger with slow deep strokes.
8. Once the large bubbles have subsided it should become increasingly more difficult to compress the master cylinder piston. Continue to do so with slow short strokes at the bottom of the piston stroke until no more bubbles appear.
9. The rubber hoses and plastic fittings may now be removed from the master cylinder.
10. Secure the master cylinder top.
11. Now test the master cylinder by "blocking off" the master cylinder ports using the correct size inverted flare plugs or bolts with the appropriate thread size for the ports on your master cylinder. Dual port master cylinders that have ports on both sides need to have all four ports plugged. The protruding cone of the inverted flare seat in the master cylinder port is made of a soft material that can easily be deformed if over tightened. If using bolts, be sure to just snug the bolts so as not to damage the cone seal surface. This cone mates with the inverted flare (expanded mouth opening) of the brake lines. If you have the ability, you can also drill a point into the end of the bolt to help prevent this from occurring.
12. Attempt to compress the master cylinder piston for approximately 30 seconds. The master should give a solid and unchanging resistance to the constant force.

13. Install the master cylinder and leave enough room on the mounting nuts to allow for some movement of the master. This will allow you some breathing room while screwing in the hydraulic lines to help prevent cross-threading the fittings.

## Bleeding the Lines

Many of you will be tempted to glaze over this section thinking that you already know this. Continue reading anyway, just bear with us. You may prevent small oversights that will cause major headaches. We have devised this to assist you in the installation of your kit and to reduce the number of technical calls in regards to these issues. Many times we get calls from people who “should have known better.” So let’s work together to make sure your installation will be as smooth as possible.

1. For master cylinder upgrades to existing power booster set ups, remove any residual vacuum in the booster by applying the brake pedal a few times with the engine off.
2. Remove the master cylinder cover and check the fluid level. Make sure it is at the appropriate level for your master cylinder, this is typically 1/2” to 1” from the lip. Be sure to check the fluid level often during the bleeding process and add fluid as necessary to prevent air from entering the master cylinder. If this happens you **MUST** start over at bench bleeding the master!
3. Replace the master cylinder cap.
4. The use of our speed bleeders will allow you to perform this job by yourself by simply cracking the speed bleeder enough to allow fluid to be forced through. The speed bleeder has an internal check valve that prevents fluid and air from returning into the caliper once the pedal is released. This removes the necessity of closing the bleeder screw before the pedal is released, allowing one person to bleed the brakes. Otherwise you will need an assistant to pump the brake pedal while you open and close the bleeder screws at the appropriate times during this process.
5. The wheel farthest away from the master cylinder is bled first which in most cases is in this order: right rear, left rear, right front, left front. Failure to bleed in the proper order will cause air to remain in the lines. This is because if you bleed a short line, (ex. front lines) before bleeding a long line (ex. rear lines), the fluid in the short line will compress and prevent enough pressure from being built up in the long line to expel the air. Furthermore, incorrect bleeding order will cause pressure to build up on one side of the proportioning valve, causing it to close on the low pressure side making it impossible to force fluid to the rear lines. If this happens you will never be able to bleed the system until you readjust the proportioning valve as described later under the heading “Test Combination/ Proportioning Valve” and then start over.
6. It may be necessary to remove the calipers from the caliper brackets while leaving the hoses attached. The calipers must be oriented in such a way as to ensure the bleeder screws point up. (See figure at right) If you bleed the lines with the calipers on the rotor, air may become trapped inside the caliper reservoir and the bleeding will be unsuccessful. The caliper should be oriented in such a way as to allow air inside the caliper internal reservoir to escape. Sometimes this

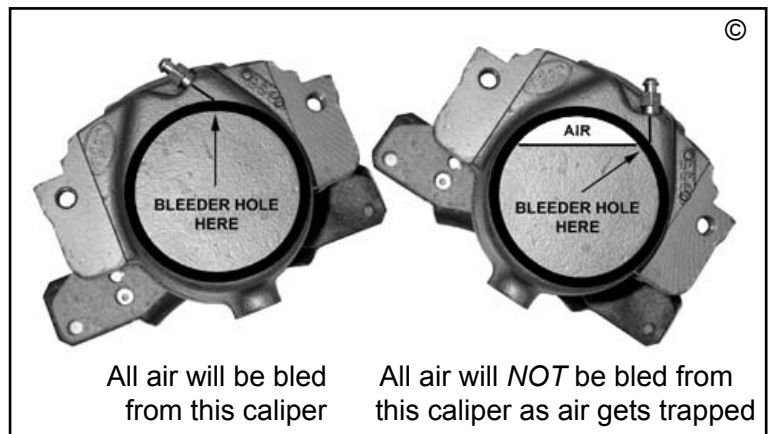

means the bleeder screw is pointing straight up and sometimes it is at a little bit of an angle. It is recommended that you do not allow the caliper to hang from the brake hose. Instead use a piece of wire or hanger to position the calipers correctly. Otherwise damage to the brake hoses may result. If you do find it necessary to remove the caliper from the rotor, be certain to insert a block that is approximately the same thickness as the rotor between the brake pads to prevent the caliper pistons from being pushed out of the caliper.

7. Crack the bleeder screws at the appropriate wheel just enough to make it easy to loosen later. Attach a length of 3/16" clear plastic, vinyl tube to the end of the bleeder screw. Submerge the other end of the tube into a container filled with brake fluid.
8. Crack the bleeder screw open just enough to allow fluid to leave the valve and have an assistant slowly and firmly apply pressure to the pedal. Have the assistant hold the pressure on the pedal until you see no more air bubbles coming out of the hose. Close the bleeder screw. Then have the assistant release the brake pedal.
9. Repeat step 8 until no more air is seen leaving the tube.
10. Close the bleeder screw to the appropriate torque for your application and proceed to the next wheel in the bleeding order, repeating steps 8 and 9 for each. Be sure to check the fluid level in the master cylinder frequently.
11. Refill the master cylinder to the appropriate level when finished with the entire bleeding process.
12. Check the pedal, it should feel solid when depressed with no sponginess and should hold under constant pressure without dropping. If necessary, repeat the entire process.
13. If you are in doubt of the effectiveness of the brake system DO NOT DRIVE THE VEHICLE!

## Brake Troubleshooting

<b>Troubleshooting Chart</b>		
<b>Symptom</b>	<b>Cause</b>	<b>Solution</b>
Not Enough Brake	• Brake Fade	• See Brake Fade on page 16
	• Vehicle is too heavy for brake system (drum brakes, added larger engine, etc.)	• Perform booster test, see page 14 • Perform master cylinder test, see page 13 • Install booster or increase booster size • Increase rotor size
Brake Light on Dash is on	• Air in lines	• Bleed Brake System • Use Speed Bleeders to facilitate bleeding
Underbraking - Car pulls to one side or one wheel locks up	• Oil or fluid on brake pad • Debris in brake lines • Collapsed lines	• Clean or replace pads and check for dirty, damaged or leaky lines or calipers
Rock Hard Pedal	• Insufficient Vacuum	• Check vacuum pressure, see Power Brake Booster Test on page 14
	• Blocked Vacuum Check Valve • Bad power booster • Frozen Wheel Cylinder • Binding Pedal linkage • Cracked Vacuum Hose	• See Power Brake Booster Test on page 14 • Replace caliper • Inspect pedal assembly • Inspect vacuum hose to booster for cracks

Spongy, Low or No Pedal	• Air in Lines	• Bleed brake system • Use Speed Bleeders to facilitate bleeding
	• Aerated Brake Fluid	• Completely flush and replace brake fluid • Check for overheating conditions
	• Parking brake out of adjustment	• Check cable setting in drums/rear brakes
	• Unequal pressure between front and rear lines	• See Combination/Proportioning Valve Test on page 15
	• Incorrect pedal ratio	• See Check Pedal Assembly on page 12
	• Bad flexible brake hoses	• See Check Flexible Brake Hoses on page 12
	• Booster pushrod out of adjustment	• Check booster installation procedures
	• Caliper misaligned to rotor because of bent caliper bracket or loose wheel bearings	• Check caliper bracket alignment • Replace wheel bearings
	• Hard lines bent above master cylinder fluid level	• Replumb hard line to remain below master cylinder fluid level to avoid trapping air in the lines
	• Master cylinder bore size too small for application	• Small bore master cylinder requires longer pedal travel to apply brakes
	• Bad power booster	• See Power Brake Booster Test on page 14
	• Air in master cylinder	• Bench bleeding the master cylinder, see page 4
	• Bad master cylinder	• See Master Cylinder Test on page 13
	• Bad or leaky Caliper	• Replace caliper
	• Master cylinder located below calipers or lines w/ no residual check valve	• See The Right Valves on pages 10
	• Drum Brakes: No residual check valves	• See The Right Valves on pages 10
	• Drum Brakes: Upgraded larger drums	• Install booster or increase booster size
	• Drum Brakes: Over arched shoes	• Replace drum, it may have been turned too many times causing not enough contact between shoes and drum
	• Drum Brakes: Oversized Wheel Cylinder for master cylinder	• Replace with larger bore master cylinder

Overheating or Dragging Brakes	• Improperly adjusted parking brake	• Check manufacturer's recommended settings
	• Pre-loaded master cylinder or power booster	• See Check Pedal Assembly on page 12
	• Bad power booster	• See Power Brake Booster Test on page 14
	• Drum Brakes: Residual check valves	• Remove residual check valve
	• Frozen parking brake cable	• Replace parking brake cable
	• Bad Calipers or wheel cylinders	• Replace caliper or cylinder
	• Overfilled master cylinder	• Fill to correct level for master cylinder, typically 1" from lip
	• Drum Brakes: Drums out of adjustment	• Drums may be adjusted too tight, readjust
Pedal too low or excessive pedal free play	• Incorrect pedal ratio • Too much space between booster pushrod and master cylinder pushrod	• See Check Pedal Assembly on page 12
Parking Brake not working	• Parking Brake out of adjustment	• Check manufacturer's recommended settings
Poor Panic Braking	• Air in lines	• Bleed brake system • Use Speed Bleeders to facilitate bleeding
	• Brake Fade	• See Brake Fade on page 16
	• Vehicle too heavy for brake system (drum brakes, added larger engine, etc.)	• Test booster, see page 14 • Test master cylinder, see page 4 • Install booster or increase booster size • Increase rotor size
	• Insufficient Vacuum	• Check vacuum pressure, see Power Brake Booster Test on page 14
	• Blocked Vacuum Check Valve	• See Power Brake Booster Test on page 14
	• Bad power booster	• See Power Brake Booster Test on page 14
	• Drum Brakes: Upgraded larger drums	• Install booster or increase booster size
	• Drum Brakes: No residual check valves	• See The Right Valves on pages 10
	• Drum Brakes: Over arched shoes causing not enough contact between shoes and drum	• Replace drum, it may have been turned too many times
	• Drum Brakes: Oversized Wheel Cylinder for master cylinder	• Replace with larger bore master cylinder

---

## Troubleshooting Bleeding Difficulties

---

If you are having difficulty getting all the air out of the system or you are not obtaining a firm pedal, try these steps to assist in the bleeding process and track down problem areas on the vehicle. A spongy pedal is usually caused by air in the system.

1. While bleeding, raise the end of the vehicle that is being bled, this may help air trapped in the system to rise towards the bleeder screw.
2. While bleeding, lightly tap the caliper with a hammer. This can dislodge air bubbles that cling to the walls of the caliper reservoir.
3. Check for damaged brake hoses that may be internally expanding from the line pressure. (See Check Flexible Brake Hoses on page 12).
4. Use line locks (vice-grips) to restrict fluid flow in the rubber lines at each wheel between the frame and the axle to help pinpoint the trouble spot. Lock all four wheels at the same time. Be aware that crushing the brake lines can damage them. To help prevent this, wrap the jaws of the line locks with a shop towel and close the line locks just enough to restrict the flow of fluid. **DO NOT OVER TIGHTEN!**
5. With the lines to all four wheels blocked off, check the pedal. You are looking for a firm hard pedal that does not drop under constant pressure over a short period of time. If you get a hard pedal, then the problem is definitely at one of the wheels. If the pedal is still spongy, first make sure the lines are effectively restricted and try the pedal again. If you still do not have a firm pedal, then remove the master cylinder to follow the bench bleed and test procedure.
6. If you do have a hard pedal, then remove the line locks from the farthest wheel from the master cylinder and press the pedal. If the pedal is spongy again, the wheel you just released is the problem wheel and requires further bleeding. (In rear disc brakes, the problem may also be that the parking brake needs adjustment. Check your parking brake adjustment before proceeding.) Make sure that all the steps for bleeding are followed. If you are still having difficulty, we suggest the use of speed bleeders to help ensure air does not return in the lines when the pedal is released. Otherwise a power bleeding system may need to be employed or a professional brake specialist may need to check the system.
7. If the pedal is still firm then continue on to the next wheel in the proper bleeding order, which is the wheel with the next longest line in the system, release the line lock at that wheel and test the pedal again. Note that it is normal to have a small amount of increase in travel as you release the line locks from each brake hose.

---

## The Right Valves

---

Using the correct valving for your application is critical to the proper operation of your brake system. There are four types of valves that perform different functions to the brake system.

- **Metering Valves** - These valves are used to equalize braking action of a Disc/Drum brake system by preventing the disc brakes from applying until about 75 - 135 psi has built up in the lines. This delays the disc brakes and allows the drums to catch up. This provides rear stability on wet surfaces and reduces front pad wear. Metering valves are generally located in the lines to the disc brakes. In most of our kits, the metering valve is a part of the combination/prop valve.



- **Proportioning Valves** - The function of the proportioning valve is to limit pressure to the rear brakes relative to pedal force, especially when high pressure is required to apply the front disc. This prevents the rear wheels from locking up as weight is shifted forward during braking. Proportioning



Valves are generally located in the brake line to the rear brakes and sometimes are incorporated into the master cylinder. They are available as either preset or adjustable valves. *Note that adjustable proportioning valves are not DOT approved for street driving and should only be used for racing applications!*

- **Residual Check Valves** - These valves are used to hold a certain amount of pressure in the lines even when the pedal is not pressed. This is a sort of preloaded line pressure to activate the brakes more quickly. They will give a higher, harder and more responsive pedal. Residual check valves should not be used as a substitute for a properly functioning system.



For instance, do not use residual check valves in place of complete and proper bleeding procedures as presented in this guide and our Brake Bleeding Guide.

Check valves will most likely be necessary when the master cylinder is lower than the calipers or hard lines run higher than the master cylinder fluid level.

In disc brakes a 2 lb. residual check valve prevents fluid from flowing back without causing the brakes to drag. With drum brakes, a 10 lb. valve is used to compensate for return spring tension in the drums. Residual check valves are generally color coded blue for 2 lb. and red for 10 lb. for easy identification.

- **Combination Valves** - These valves offer multiple functionality in a single unit. They combine the functions of both a metering valve and a proportioning valve with the addition of a brake light warning switch. The brake light warning switch signals when there is an imbalance of pressure in the system caused by a problem in the front or rear brakes. They are by far the best valve to use for all disc brake conversions. All our kits use DOT approved Combination Valves designed specifically for either Disc/Disc or Disc/Drum applications.

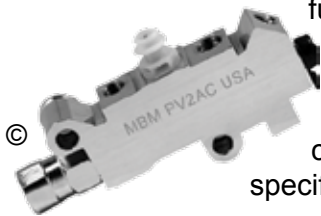

### Check Booster Pushrod Adjustment

The pushrod that actuates the master cylinder must be properly adjusted. Ideally there should be only slight clearance between the booster pushrod and the master cylinder pushrod. Interference will preload the master cylinder. When the system is preloaded, it builds pressure each time the pedal is pressed. Since the master cylinder is not allowed to fully release the pressure from the previous stroke, the system will eventually lock the wheels. Too much clearance will cause excessive free play in the pedal.

There are basically two different master cylinders that we use for our Chevy and Ford kits, the deep bore master cylinder and the shallow bore master cylinder. To determine which master cylinder your booster is setup to mate with, you can do the following simple check. For shallow bore master cylinders, the pushrod should be approximately flush with or below the booster face. Deep bore master cylinders will protrude past the face of the booster body by about 1" to 1-1/2". Note that deep bore master cylinders are required for manual brakes and shallow bore master cylinders are generally used for power brake systems. We now supply a master cylinder piston adapter (pictured) to accommodate both master cylinders. You will only use this adapter when you have a deep bore master cylinder with a short booster pushrod.



---

## Check Flexible Brake Hoses

---

Inspect the flexible brake hoses for typical signs of fatigue. Hoses should be checked for:

- **Damage:** Check for large surface cracks, scuffing or worn spots. If the outer casing has severe cracks or abrasions, the hose need to be replaced. The casing is the protection for the hose, if it is damaged, the deterioration of the hose can take place with possible burst failure. Lines should be flexible and firm rather than hard and stiff.
- **Faulty Installation:** Twisting the hose or rubbing against wheels, tires or chassis will cause premature line deterioration.

Make sure that the tube and hose mating surfaces are clean and free from nicks and burrs. New seal washer(s) should be used. Double wall steel tubing should always be used to replace hard lines. Care should be taken when replacing brake tubing, to use the proper bending and flaring tools and to avoid kinking, routing the tubes against sharp edges, moving components, in hot areas or above the master cylinder fluid level. All tubes should be properly attached with appropriate retaining clips and tabs.

---

## Check Pedal Assembly

---

Something that many people are not aware of when upgrading their system is the brake pedal adjustment. Improper pedal adjustment can do the following:

- Preload the booster causing brakes to drag and eventually lock up.
- Damage the booster's internal components by actuating at an improper angle.
- Allow slop in the pedal if adjusted too low.

Many vehicles have a second hole on the pedal assembly that was originally intended for power brake applications. The required hole is generally 1" to 1-1/2" lower than the original manual brake hole. If there is no second hole, you may need to drill the hole in the pedal arm to properly align the push rod. The easiest way to determine the perfect location for this hole is to find the center of the push rod's vertical travel to ensure that its actuation is as in line with the booster as possible.

1. Gently lift the end of the pushrod until it stops and note the location where the clevis on the pushrod locates on the pedal arm. Mark this location.
2. Then gently push the pushrod down until it stops. Mark this location as well.
3. The **proper hole location** is in the middle between the two marks on the pedal arm. Mark and drill the new hole in the center of the pedal arm. Attach the pushrod to the pedal arm.
4. Check free play in the pedal by applying pressure to the pedal with your hand and noting how far the pedal travels before resistance is felt. It should be approximately 1/4". This free play allows the master cylinder piston to return to the "at-rest" position and prevents preloading the system. Too much free play will drop the pedal too far before applying brake pressure and may even hit the floor before applying full braking force to the system. Note free play is also dependent upon proper adjustment of the booster pushrod.

## Check Proper Caliper Alignment

The proper alignment of the calipers is critical to a safe brake system and in preventing premature wear of the rotors and pads. It may be necessary to grind small protrusions on the caliper to ensure a proper fit and alignment of the calipers on the caliper brackets. DO NOT grind on the caliper brackets, this will weaken the design of the brackets and may lead to brake failure. Be aware that grinding can produce a tremendous amount of heat. Because of the relatively thin amount of material of the plate, subjecting the brackets to this heat may causing them to become brittle and break under stress.

If the wheel flange is warped causing the caliper and bracket to not align properly with the rotor, insert one or two washers between the wheel flange and the caliper bracket. Use the washers to shim the assembly and align with the rotor as necessary.

## Master Cylinder Test

Note that this test of the master cylinder requires a complete re-bleeding of the system since the brake lines are removed from the master to perform this test. This is why we include this test during the bench bleeding process. However, just because you have performed the test during bench bleeding does not mean that air has not entered the master cylinder since then. Should air enter the master cylinder at any time after bench bleeding, the master cylinder **MUST** be removed from the vehicle and bench bled again. A number of things can cause air to enter the master cylinder:

- If the fluid levels drop too low during the bleeding process.
- If the master cylinder was left sitting for too long after the bench bleeding before having the lines installed.
- Mishandling of the master cylinder such as if it were dropped or jarred excessively.

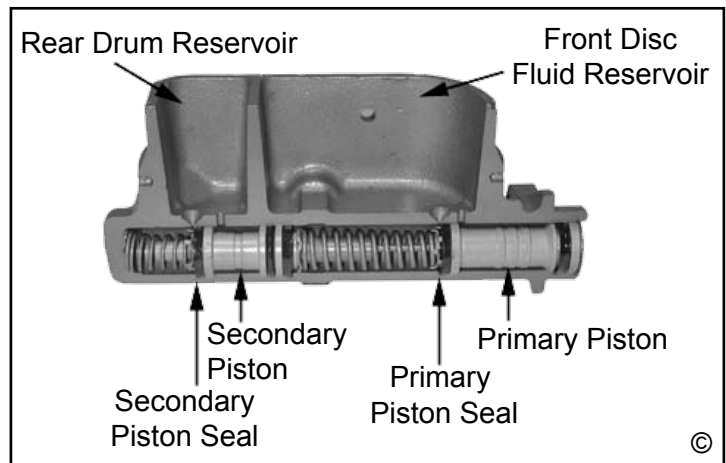

To test the master cylinder:

1. Remove the brake lines from the master cylinder ports.
2. Block off the master cylinder brake line ports using the correct size inverted flare plugs or bolts with the appropriate thread size for the ports on your master cylinder. Dual port master cylinders that have ports on both sides need to have all four ports plugged. The protruding cone of the inverted flare seat in the master cylinder port is made of a soft material that can easily be deformed if over tightened. If using bolts, be sure to just snug the bolts so as not to damage the cone seal surface. This cone mates with the inverted flare (expanded mouth opening) of the brake lines. If you have the ability, you can also drill a point into the end of the bolt to help prevent this from occurring. Most GM master cylinders use 9/16-18 threads for the front ports and 1/2-20 threads for the rear ports. Most Ford master cylinders use 3/8-24 threads for the front ports and 7/16-24 threads for the rear ports.
3. Apply constant pressure to the pedal, the pedal should be firm, hard and should not drop over time.

- If the pedal is squishy there may be air in the master cylinder. Bench bleed the master according to the instructions above and test again.
- If the pedal is firm and then drops over time under constant pressure, the master cylinder should be replaced.

### Power Brake Booster Test

If the pedal feels “hard” while the engine is running, the booster isn’t operating correctly. If you suspect the booster is defective, do not attempt to disassemble or repair the power booster. Doing so is unsafe and will void your warranty.

#### Test 1

- With the engine off, pump the brake pedal to remove any residual vacuum in the booster.
- Hold pressure on the pedal while you start the engine. When the engine starts, the pedal should drop about a 1/4”, this indicates that the booster is working properly.

#### Test 2

- Run the engine a couple of minutes.
- Turn the engine off and press the pedal several times slowly. The first pump should be fairly low. The second and third should become slightly firmer. This indicates an airtight booster.

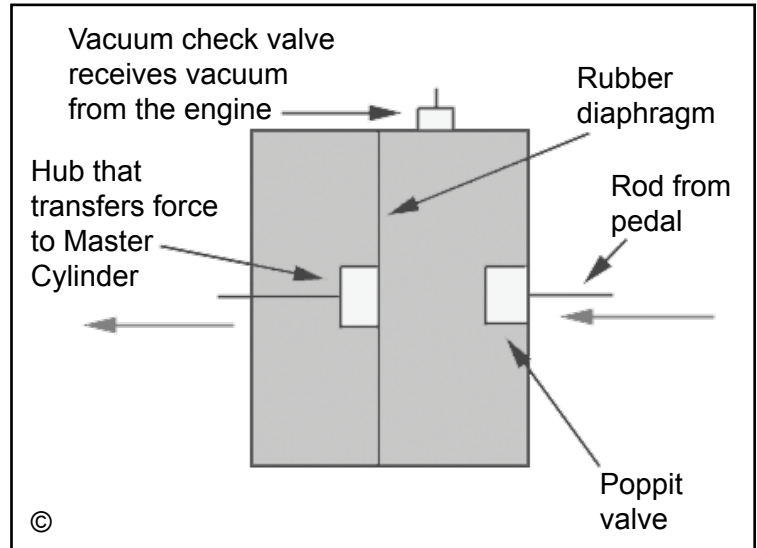

#### Test 3

- Start the engine and press the brake pedal, then stop the engine with the pedal still pressed. If the pedal does not drop after holding the pressure on the pedal for 30 seconds, the booster is airtight.

#### Test 4 - Inspect the Check Valve

- Disconnect the vacuum hose where it connects to the intake manifold. Do not disconnect the vacuum line from the booster. Air should not flow when pressure is applied, but should flow when suction is applied. If air flows in both directions or there is no air flow, the valve needs to be replaced.

#### Test 5 - Verify Enough Vacuum

- Check the operating vacuum pressure when the engine is at normal operating temperature. There should be a minimum of 18 in. of vacuum. Vacuum may be increased by properly tuning the engine, checking for vacuum leaks and blockages in vacuum lines.

## Combination Prop Valve Test

1. Use a test light by attaching a clip to a positive contact on the vehicle and touch the point of the tester to the electrical connection of the combination valve. If the light does not come on, the valve system is operation correctly and no further testing is required.
2. If the light does come on, this indicates that the pressure differential valve is stuck in the front or rear position.

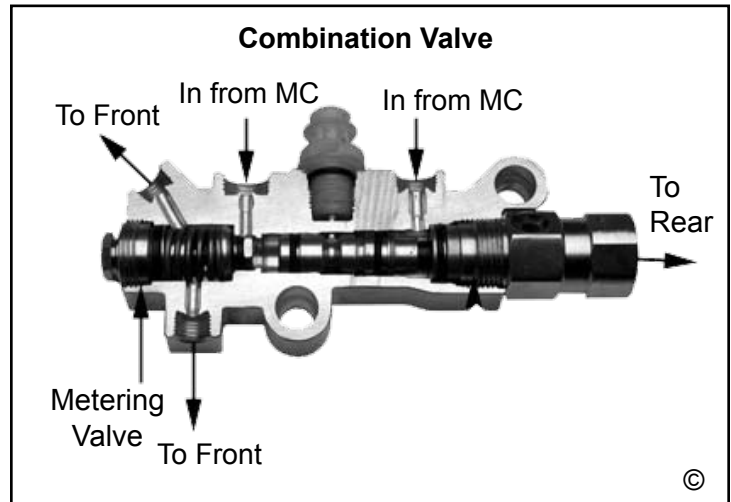

3. Bleed the brake system to determine if the front or rear lines are blocked off. Set up one front wheel and one rear wheel for bleeding at the same time. Crack both bleeder screws and gently pump the pedal a few times. The blocked side will trickle fluid out when the bleeder screw is cracked and the pedal pressed. An unblocked line will squirt fluid out the bleeder.
4. The lines that are clear must be left open and the blocked lines should have the bleeder screws tight to cause pressure to build up on that side. Be sure to use the standard bleeding procedures to prevent air from entering the system.
5. Slowly press the pedal with steady pressure a number of times until the light goes out; this will center the differential valve. You may also hear a pop come from the proportioning valve. This is the metering valve returning to its equalized position. When the light goes out, close the bleeder screw.

## Sticking Proportioning Valve

1. Bleed the brake system to determine if the front or rear lines are blocked off. Set up one front wheel and one rear wheel for bleeding at the same time. Crack both bleeder screws and gently pump the pedal a few times.
2. The blocked side will trickle fluid out when the bleeder screw is cracked and the pedal pressed. An unblocked line will squirt fluid out the bleeder.
3. The lines that are clear must be left open and the blocked lines should have the bleeder screw tight to cause pressure to build up on that side. Be sure to use the standard bleeding procedures to prevent air from entering the system.
4. Slowly press the pedal with steady pressure a number of times until the light goes out. This will center the differential valve. You may also hear a pop come from the proportioning valve. This is the metering valve returning to its equalized position. When the light goes out, close the bleeder screw.

---

## Brake Fade

---

Brake fade is a gradual loss of braking power that can be caused by old brake fluid or overheated brakes. Overheated brakes is a very dangerous situation which can cause old or contaminated brake fluid to boil. The gases released from boiling brake fluid will cause a squishy pedal even after the brakes have cooled and can cause brake failure if not immediately taken care of. This is all the more reason to ONLY use brake fluid that is from a newly opened sealed container. Drum brakes can compound the problem of overheated brakes. Since the drum itself expands when heated, it increases the amount of travel required by the shoes to effectively stop the vehicle. Brake fade can also occur in drum brakes by the accumulation of water inside the drum since it traps water inside. The water then acts as a lubricant between the shoes and the drum, causing ineffective braking.

## Typical Brake System Configurations

Figuring out how to plumb your brake system is quite simple. The two qualifying questions are:

1. Is your brake system: Disc/Disc, Disc/Drum, or Drum/Drum? Because...
  - Drum brakes require a 10 lb. residual pressure (RPV10) to counteract the spring tension in the drum system which tends to pull the shoes away from the drums.
  - Disc Brakes require a combination valve (often called a proportioning valve) and sometimes a 2 lb. residual valve- depending on where your master cylinder is relative to your calipers (see next bullet).
2. For disc applications; Is your Master Cylinder mounted above or below your calipers? because...
  - If your master cylinder is below your calipers then a 2 lb. residual valve (RPV2) is needed to prevent fluid from flowing back from the calipers into the master cylinder.

---

## Quick Reference Guides

---

1. **Drum Brakes Front and Rear with Master on Firewall or Under Floor** - Drum brakes require a 10 lb. residual pressure (RPV10) to counteract the spring tension in the drum system which tends to pull the shoes away from the drums. This will give you a longer pedal travel and "spongy" brakes. The residual valve holds a pressure keeping the shoes near the drums giving a higher firmer pedal. Also required a metering valve (PVM) to the front (the metering valve prevents nose dive).

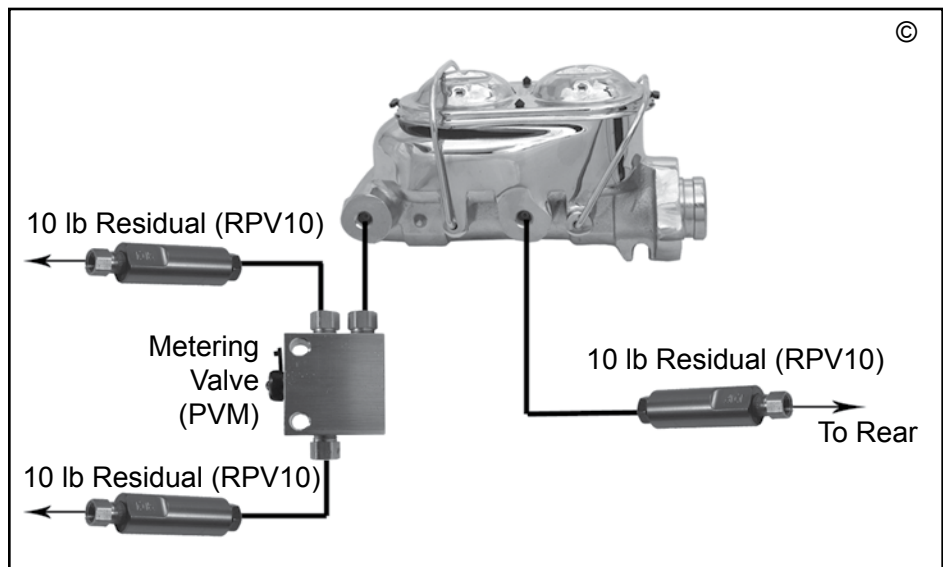

2. **Disc Brakes Front and Drums Rear with Master on Firewall** - A disc/drum combination valve (PV2) is the easiest way to properly balance your braking system. The combination valve is two valves in one. It provides metering to the front which prevents nose dive and proportioning to the rear which prevents rear wheel lock up. We also recommend the addition of a 10 lb residual valve (RPV10) to the rear drum brakes.

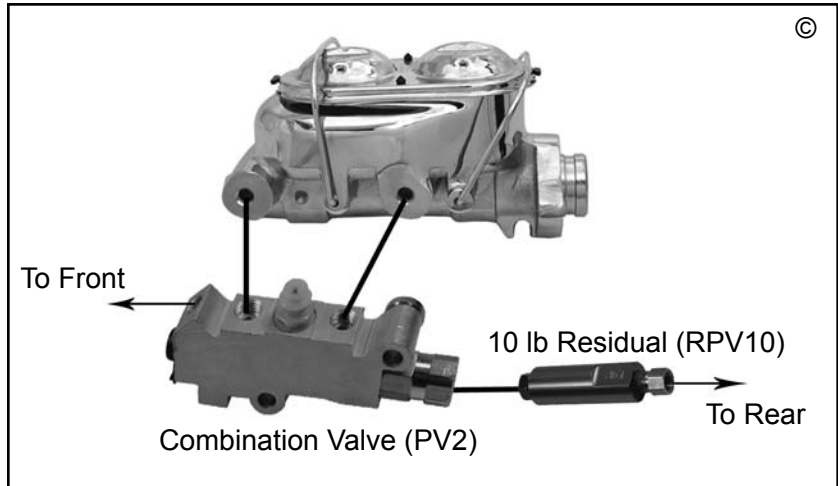

3. **Disc Brakes Front and Drums Rear with Master Under Floor** - The best way to plumb a disc/drum system when the master is under the floor is with a combination valve (PV2) and then a 2 pound residual valve (RPV2) to the front which is needed to prevent fluid from flowing back from the calipers into the master. We also recommend the addition of a 10 lb residual valve (RPV10) to the rear drum brakes.

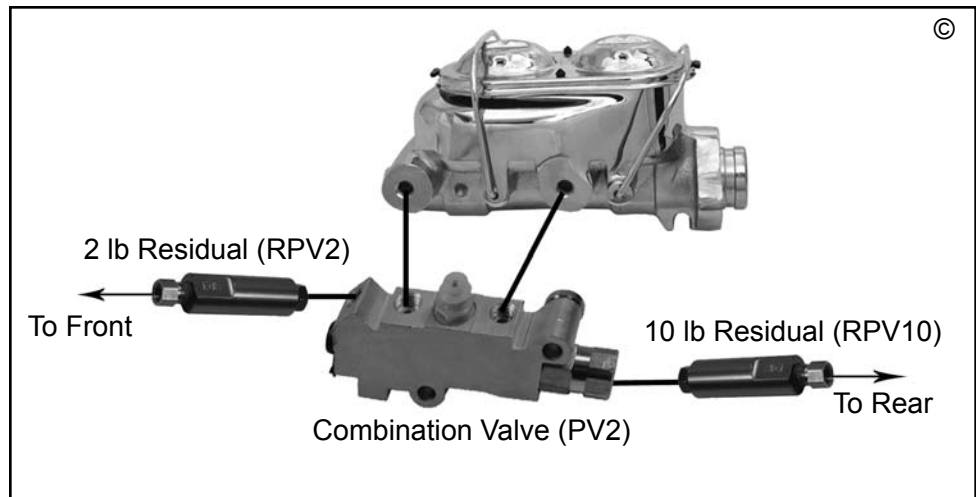

**How to Plumb Your Rod For Disc/Drum System and Master Under Floor**

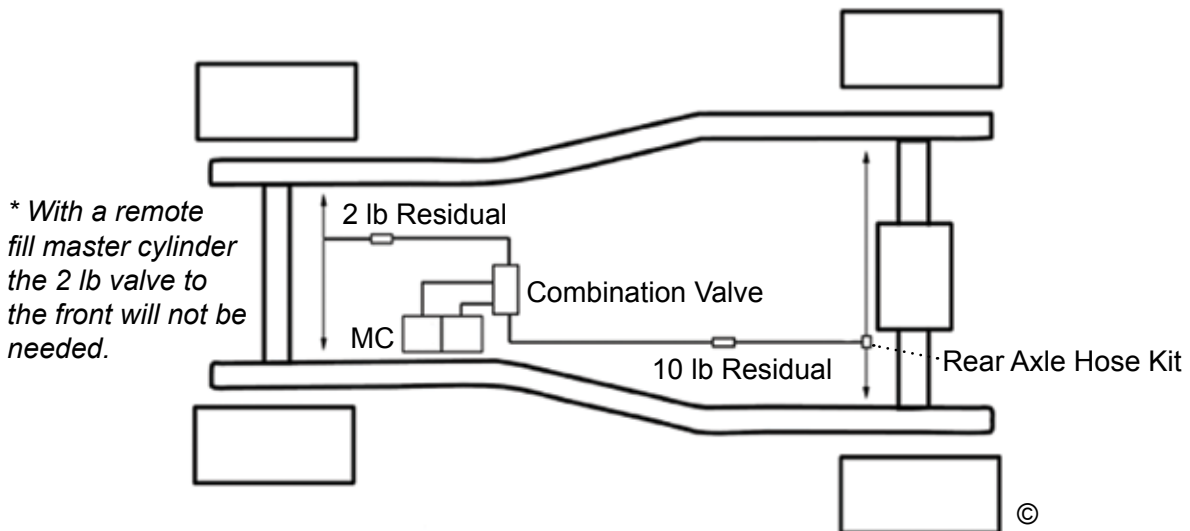

4. **Four Wheel Disc with Master on Firewall** - The best way to plumb a disc/disc system when the master is on the firewall is with a four wheel disc brake combination valve (PV4).

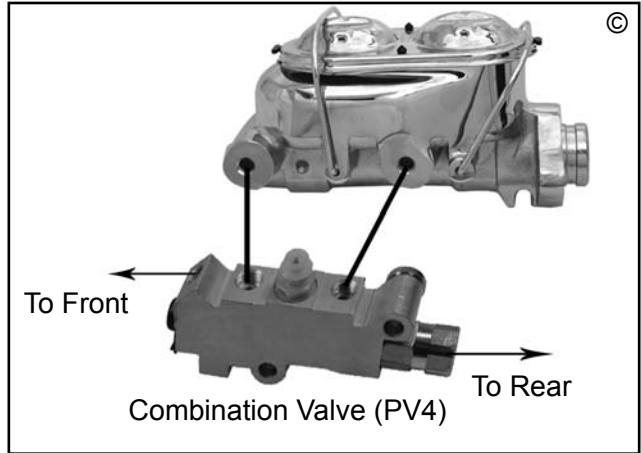

5. **Four Wheel Disc with Master Under Floor** - The best way to plumb a disc/disc system when the master is under the firewall is with a four wheel disc brake combination valve (PV4) and a two pound residual valve (RPV2) to the front and a two pound residual valve (RPV2) to the rear.

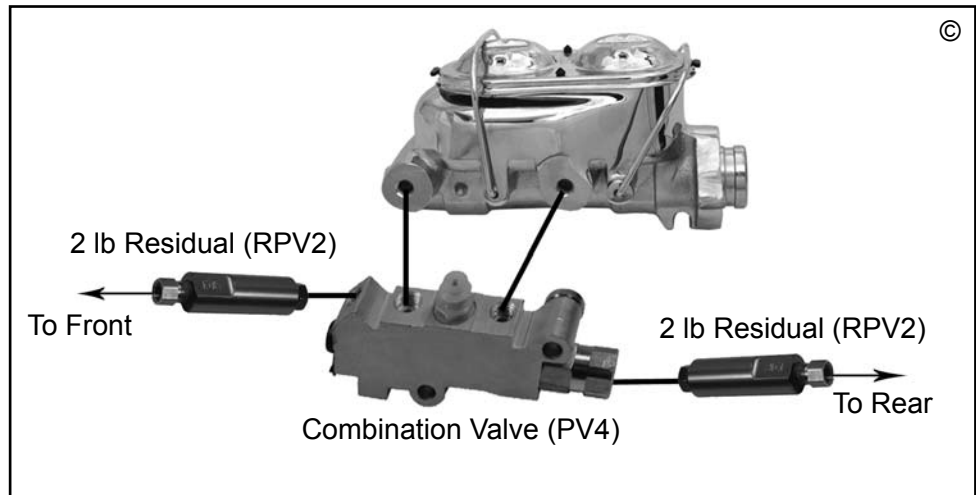

**How to Plumb Your Rod For Disc/Disc System and Master Under Floor**

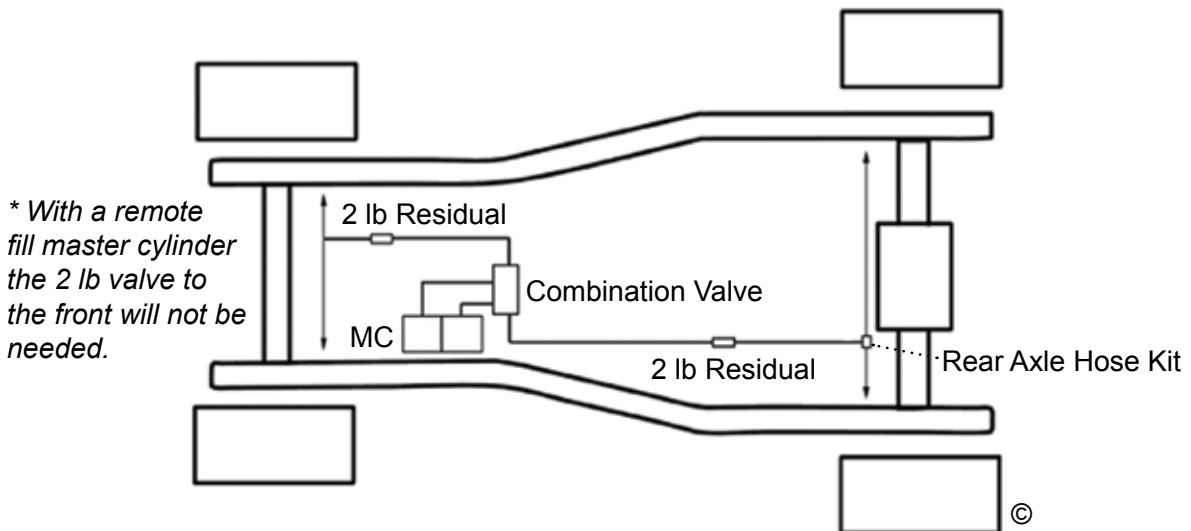

*Let us fill all your Brake, Steering and Suspension Needs*

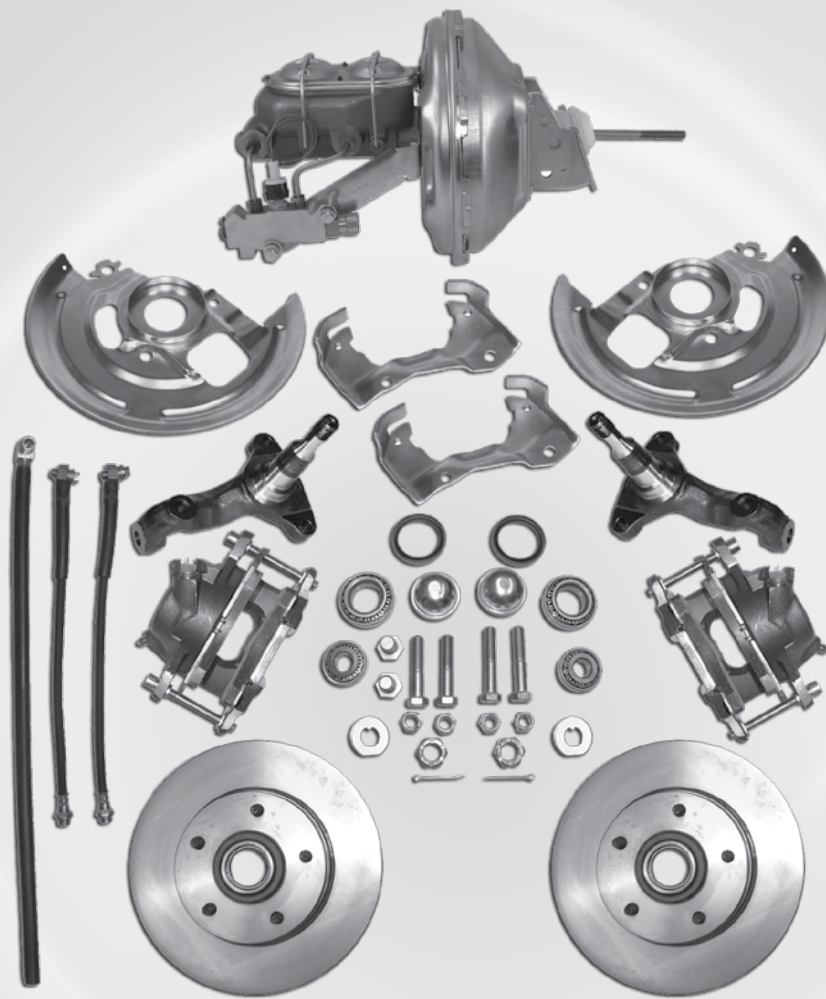

*Disc Brake Kits*

*Rotors*

*Calipers*

*Power Brake Units*

*Pedals*

*Booster Conversion Kits*

*Power Brake Boosters*

*Master Cylinders*

*Proportioning Valves*

*Proportioning Valve Kits*

*Proportioning Valve Lines*

*Spindles and Steering*

*Water Pumps and Alternators*

*Hydro-Boost Rebuild Kits*

*Brackets & More*

*Contact us at 800-231-4125 and Discover the MBM Advantage!*

## MBM

27 Mulvaney Street  
Asheville, NC 28803

p 800-231-4125 or 828-285-0882  
f 800-331-1626 or 828-285-0877

[www.mbmbrakeboosters.com](http://www.mbmbrakeboosters.com)  
[info@mbmbrakeboosters.com](mailto:info@mbmbrakeboosters.com)



*Discover the MBM Advantage!*