



PERFORMANCE USA LLC

Feb 14, 2017

1967-1969 Camaro ExtReme Tunnel Cover

Part number 11510



Installation Instructions

The following instructions are intended for professional installers and are guidelines only. Speedtech Performance assumes NO responsibility for the installation of any of its products. All products are intended for off road use only and must be installed by qualified professionals only. Read all instructions through before beginning.

Thank you for purchasing your new Speedtech Extreme Transmission Tunnel Cover. If you are unsure how to use the tools and materials required to install this cover, stop and seek a professional installer's help. Take all necessary precautions whenever jacking up your vehicle and be sure to use safe and sturdy jack stands to support the vehicle whenever it is off the ground.

This Tunnel Cover can be installed with basic hand and power tools. You will be required to drill some holes, cut a hole in the floor for transmission clearance and a hole in the Tunnel Cover for the shifter. Be sure to wear the proper protective gear when using power tools. You will also need two small pieces of scrap 16 ga. sheet metal (step 4) and seam sealer.

If you plan to weld the cover to the floor, be sure to take necessary precautions when welding inside a vehicle and remove any close-by flammable materials. Although not completely necessary, we have found it easiest and safest to completely remove the carpet from the car to perform this installation.

NOTE: This tunnel cover has been designed around the T56 Magnum aftermarket transmission and it's associated shifter locations. Some factory OEM transmissions put the shifter in a different location, for example Viper, '98-02 Camaro, GTO, etc. Some adjustment and/or modification to the tunnel and/or Tunnel Cover may be required in those cases. For your convenience a diagram of all tunnel measurements is at the end of these instructions.

1. Find the final location for engine and transmission fitment within the car's frame. Find and mark the approximate shifter arm location on the transmission tunnel. Considering your mark of where the shifter will be located, mock up the tunnel cover in it's location on the interior of the car. The large open end goes towards the front. Trace a few of the pre drilled holes in the cover onto the floor pan for future alignment purposes and for help in laying out cut lines. See **(A)** in the diagram on the following page.

2. Mark out your cut lines. They should be at the top of the sides of the tunnel and extend approximately 19.5" behind and 4" forward of the factory overlap pinch weld area, refer to the diagram on the next page. This should be close to the proper fitment, although further minor trimming may be necessary. Be sure to leave enough metal for the tunnel cover to overlap on all sides. Remember measure twice, cut once. Remove this section from the top of tunnel.

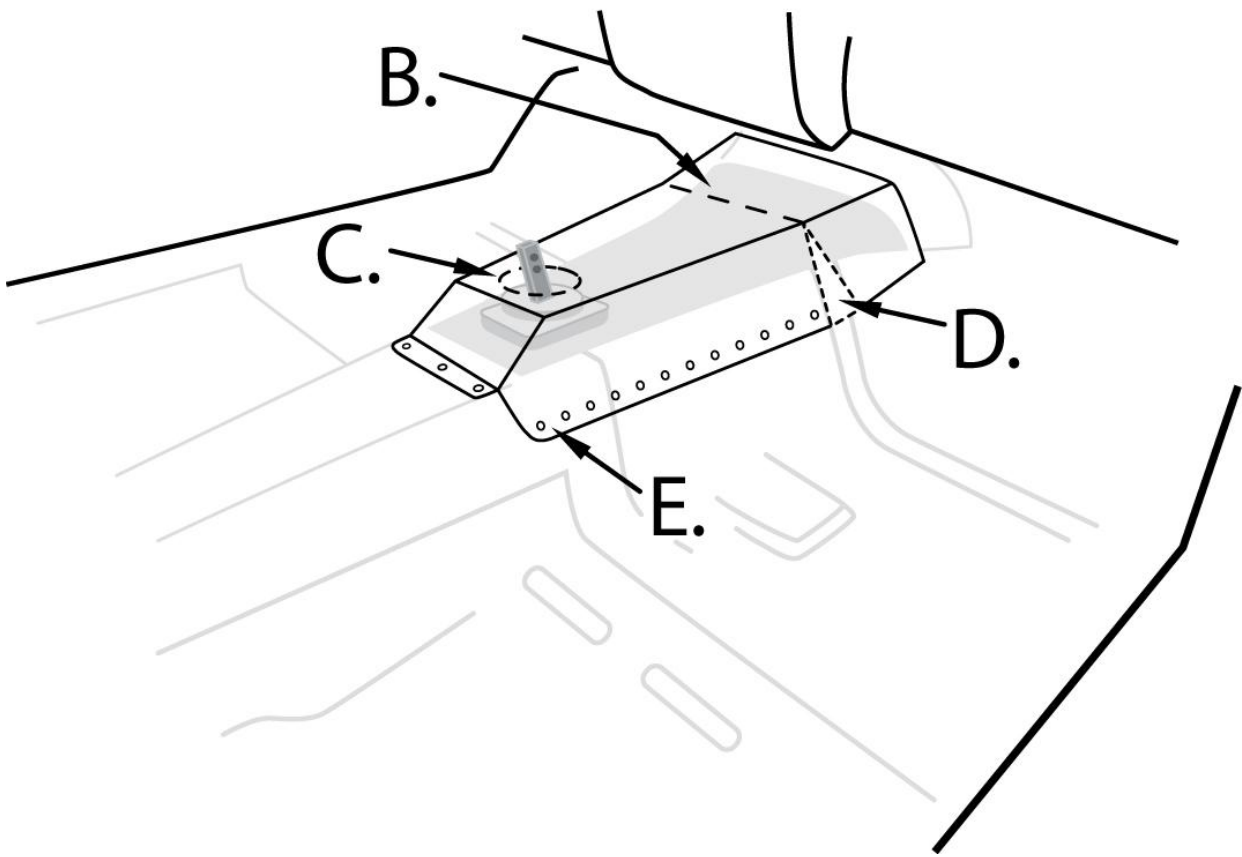
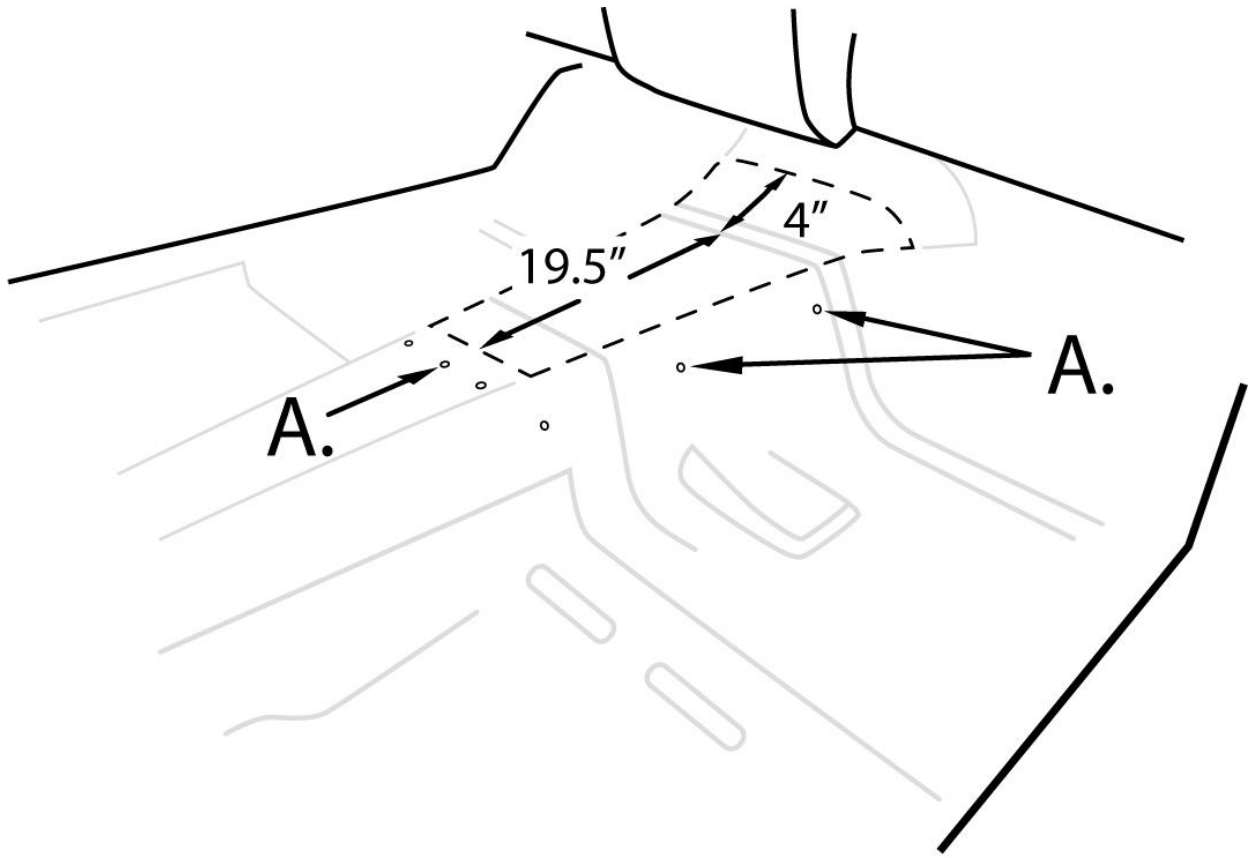

3. The front portion of the cover will need to be bent upward at the cut lines located on each side of the cover. This will help it better conform to the shape of the car's floor pan and bell housing area, see **(B)** on the previous page. Some hammer and dolly reshaping of the tunnel cover as well as the bell housing area and sides of the tunnel will be necessary for a closer fit to each other. Once the tunnel cover fits snug, mark and cut a hole in the tunnel cover centered over where the shifter will be located approximately, 3³/₄" (3.75) in diameter. See **(C)** in the diagram on the previous page and the photo below.



4. Bending the front portion of the cover upward will create a small pie shaped open area. **(D)** These areas will need to be filled with a scrap piece of 16 gauge flat steel. If you plan to weld this area we recommend welding it together outside of the car to prevent flying sparks and possible fires on the interior.

5. Once you feel comfortable with the fit of the tunnel cover, both in the interior and under the floor pan, begin attaching the cover to the floor using the convenient pre-drilled holes. **(E)** This may be done in several ways, for example plug welding, rivets, sheet metal screws, etc. There are no pre-drilled holes towards the front because there may be some trimming and shaping to fit different cars. Drill these holes after modification is completed so you can properly secure the front of the tunnel as well.

6. Once the cover is properly and securely fastened to the floor, be sure to seam seal all areas on top *and* underneath where the tunnel cover meets the floor. The end result will look similar to this cover installed in a 1970 Nova.



7. Cover your tunnel cover as fits your needs. As seen below we recommend splitting and securing vacuum tubing around the diameter of the shifter hole in the tunnel cover to prevent the metal gouging the shifter boot.

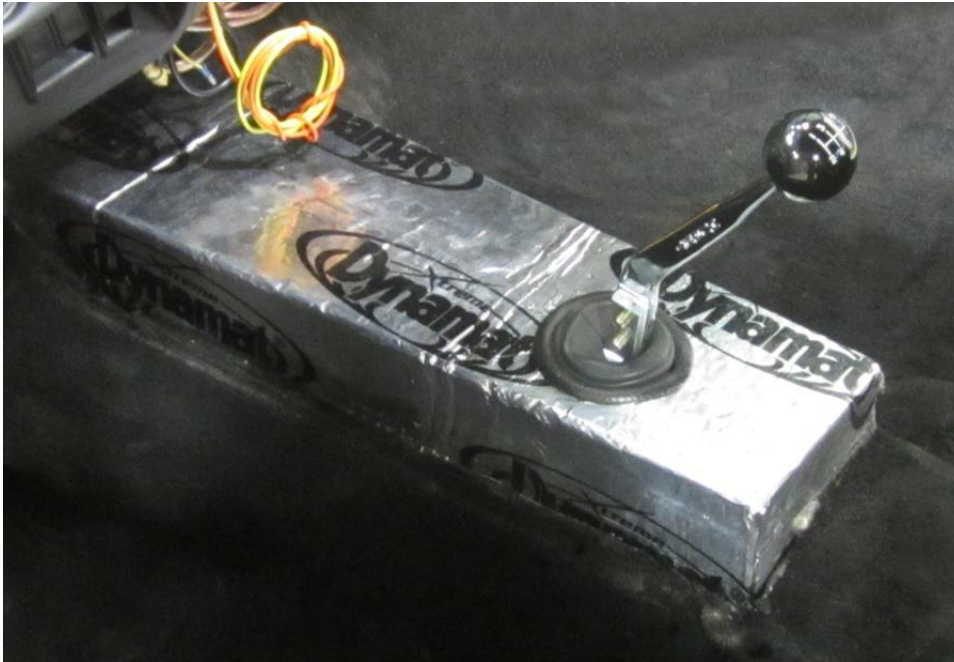

11510
'67-69 Camaro w/T56
Extreme Tunnel Cover

Front Perspective

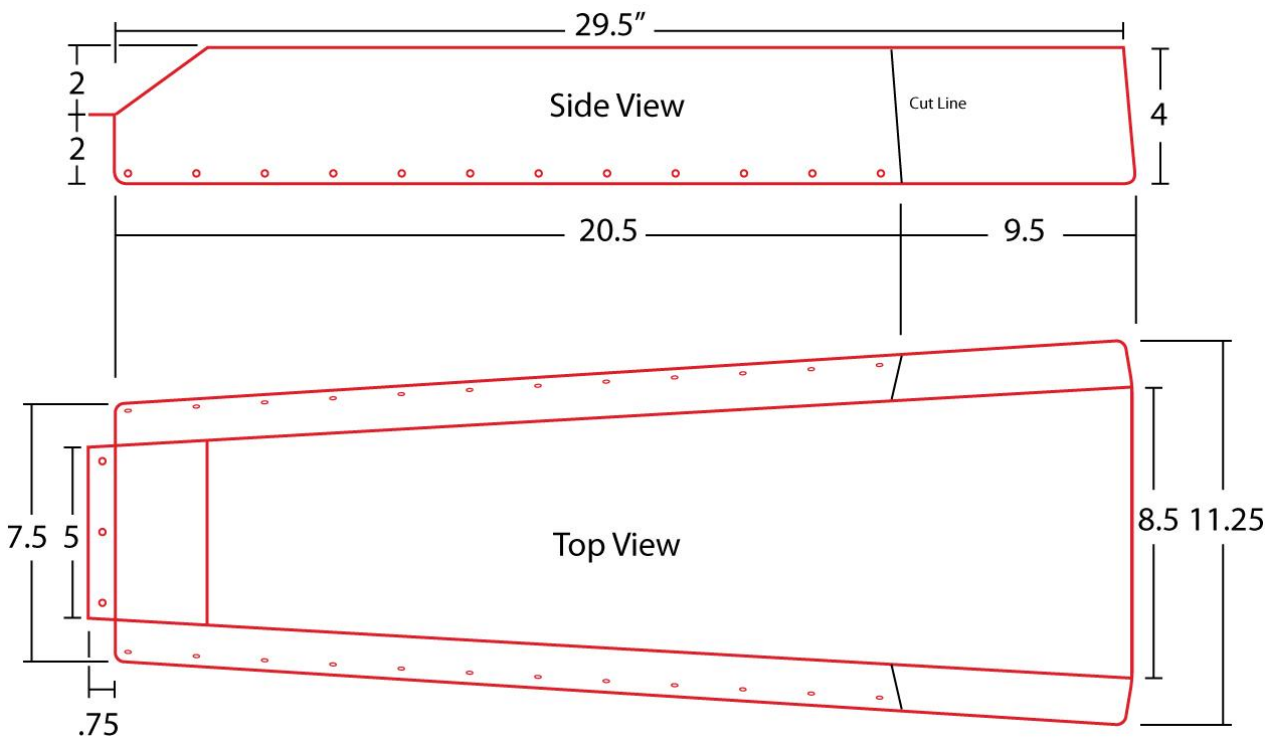

Speedtech Performance USA, LLC
3884 S. River Rd. St. George, UT 84770
435-628-4300

1. Terms and Conditions of Sale

1. Effective January, 2008, supersedes all previous policy statements. Policies are subject to change without notice. Speedtech Performance Ltd. is not responsible for printing errors.
2. Speedtech Performance USA LLC. does not endorse, nor recommend modification of vehicles for use on public highways, since warranty or government regulations may be violated. As an express condition of sale of any performance part, the buyer acknowledges and agrees to use the performance parts for the modification of vehicles in sanctioned OFF-ROAD competitive events and show purposes only. Customers should exercise their discretion on matters with regards to the purchase and installation of these products.
3. Speedtech Performance USA LLC. does not ensure the legal use of these products. We do not guarantee the fitment of these products for anything other than their intended application nor do we assume any responsibilities whatsoever for the misuse or losses incurred by the use of any of these components. While every effort is made to provide technical information and assistance, we have no control over owner installation, modification, and unusual stress that performance parts are subject to.
4. The customer acknowledges that Speedtech Performance USA LLC. and its employees are not responsible for any mechanical failures due to the use of parts sold, supplied or installed not for their intended application. Speedtech Performance USA LLC will not be held liable for any damages which are incurred directly or indirectly on the vehicles or operators or passengers of the vehicle.
5. Please consult your sales agent and/or technician prior to purchase of any of Speedtech Performance USA LLC products to ensure proper fit. The buyer assumes all responsibilities for determining the suitability of the product. All aftermarket products should always be installed by professionals only.

2. How to File a Warranty Claim:

1. Speedtech Performance Ltd. warrants its products against materials and workmanship failure for the term of 12 months (1 year) from the date of purchase and only up to the amount paid with proof of purchase.
2. Seller's liability shall be limited to repairing or replacing, at its option, any defective product which is returned, freight prepaid to Seller, according to the Merchandise Return Procedure set forth in Section 3-B below. Buyer shall bear all responsibility for shipping charges and risk of loss or damage during transit to Seller. Products which have been subjected to abuse, misuse, alteration, neglect or unauthorized repair or installation, as determined solely by Seller, are not covered by this warranty. Any alterations, addition, improvements or attachments to the product(s) not authorized in writing by the Seller shall be deemed to be a waiver of this warranty by Buyer and shall render this warranty null and void. Seller shall return repaired or replaced product(s) to Buyer, at its expense via regular ground service in the U.S. Shipping charges by all other methods and to all other destinations shall be borne by Buyer.
3. As per section 3-B below, all shipments MUST be prepaid, include the original invoice and show the RGA on the outside of the package, otherwise it will be refused. Please include a brief explanation letter in order to expedite the warranty analysis process.

This Warranty DOES NOT Cover-

- Removal, installation, shipment and insurance costs
- Improper installation or maintenance
- Alterations on the original design or unauthorized repairs.
- Normal wear and tear
- Misuse or abuse, negligence
- Damage to related components
- Costs incurred due to down time of vehicle

3. Merchandise General Return Procedure:

A. If you purchased your Speedtech Performance USA LLC product from us or from an authorized dealer, you are covered by the terms of our general product return policy. All claims however, must be submitted directly to Speedtech Performance USA LLC. The answer to ALL of the following questions should be YES before contacting our Customer Service Department.

1. Is the part appropriate to your application?
2. Did you carefully and thoroughly read the instructions provided along with the part?
3. Do you have the proof of purchase?
4. Are you the original purchaser?
5. Is the part unmodified and clean?
6. Is the return date within 3 months from the purchase date?
7. Is the reason for return a legitimate product defect?

If all answers are yes, please do the following:

B. Call our customer service representatives at 1-435-628-4300.

- Provide the invoice number, date of purchase and reason for return
- You will be assigned a Returned Goods Authorization Number (RGA) valid for 30 days. The package you return must show the RGA on the outside of the package, include a copy of the original invoice and be shipped prepaid to our facility. The part has to be in its original packaging materials and be in a resellable condition. ***For parts presenting signs of installation and/ or use, only warranty claims will be accepted.***
- Ship to seller, *freight pre-paid* and insured for replacement cost in original packaging.
- Replacement or repair decision will be made when merchandise is received by seller. No advance replacement is available.
- A Restocking fee may be applied.

All warranties implied by law are limited in duration of this warranty. You have specific rights that may vary from state to state or Province to Province. By purchasing any of the products that are manufactured by speedtech performance you agree to any and all of the above terms and conditions. **Copyright © Speedtech Performance USA LLC**